

# Brass Ball Valve



**2 Piece • Full Port • Threaded Connection • 600 WOG •  
Stainless Steel Ball and Stem**



**T-100SSE**

CRN# 0C16887.5469870YTN

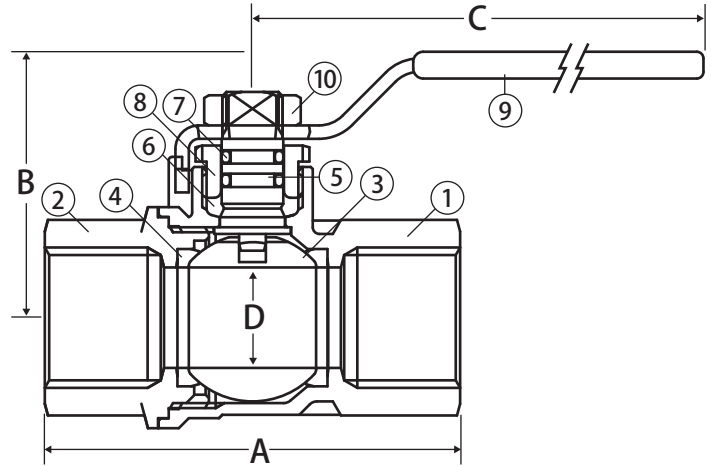

## Material Specifications

No.	Part	Materials
1	Body	T.E.A. Coated Brass - CW617N
2	End Connection	T.E.A. Coated Brass - CW617N
3	Ball	316 Stainless Steel
4	Seat (2)	Hostaflo <sup>®</sup> TFM 1600
5	Stem	316 Stainless Steel
6	Packing	Hostaflo <sup>®</sup> TFM 1600
7	Stem O-ring (2)	Viton <sup>®</sup>
8	Packing Gland	Nickel Plated Brass - CW614N
9	Handle	Steel - Geomet <sup>®</sup> Plated
10	Handle Nut	Steel - Geomet <sup>®</sup> Plated

## Dimensions

Part No.	Size	A	B	C	D	Cv
100-501	1/4"	1.86	1.41	2.95	0.39	7.66
100-502	3/8"	1.86	1.41	2.95	0.39	7.77
100-503	1/2"	2.45	1.53	2.95	0.59	16.82
100-504	3/4"	2.71	1.95	3.74	0.79	34.80
100-505	1"	3.30	2.40	4.75	0.97	52.20
100-506	1-1/4"	3.80	2.59	4.75	1.23	112.52
100-507	1-1/2"	4.16	3.22	6.00	1.49	174.00
100-508	2"	5.00	3.40	6.00	1.99	255.20
100-509	2-1/2"	6.06	4.60	8.00	2.46	350.32
100-510	3"	7.08	4.90	8.00	2.99	563.76

## Features

- Blow-out proof stem
- T.E.A. Ternary Eco Alloy<sup>®</sup> coated body, which prevents dezincification and galvanic corrosion
- Triple sealing stem with 2 Viton<sup>®</sup> o-rings and Teflon<sup>®</sup> seal
- 100% leak tested
- 100% Made in Italy
- Leakproof stem - Lifetime Warranty
- 29 in-Hg vacuum rating
- Accessories available

## Approvals

- CSA Certified
  - ASME B16.33 (125 PSIG) (1/2" - 2")
  - CGA 3.16 (125 PSIG) (1/4" - 2")
- FM Approval (1/4" - 2")
- ANSI B1.20.1
- MSS SP-110

## Valve Seat Rating

1/4" - 3/4" 600 WOG, 1-2" 500 WOG, 2-1/2" - 4" 400 WOG - 150 WSP

