

Lead Free Brass Inline Check Valve

Jomar VALVE LEAD FREE

Threaded Connection • 300 WOG • Class 150

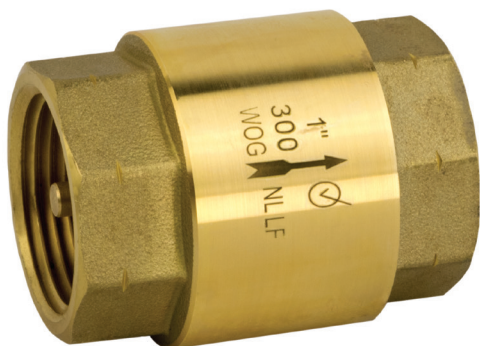

T-521G

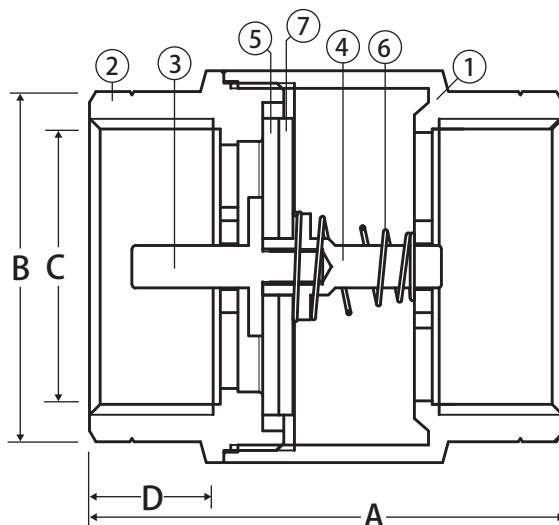

Features

- Forged Lead Free Brass Body
- Bubble tight Teflon seal
- Wetted surfaces contain less than .25% lead content

Approvals

- Lead Free Compliant
- ANSI B1.20.1

Pressure/Temperature Rating

- 300WOG
- Max. 250°F

Material Specifications

No.	Part	Materials
1	Body	Lead Free Brass
2	Tailpiece	Lead Free Brass
3	Disc Holder 1	Lead Free Brass
4	Disc Holder 2	Lead Free Brass
5	Disc	PTFE
6	Spring	304 Stainless Steel

Dimensions

Part No.	Size	A	B	C	D
105-603G	1/2"	1.28	1.91	0.50	0.49
105-604G	3/4"	1.54	2.06	0.75	0.59
105-605G	1"	1.77	2.30	1.00	0.59
105-606G	1-1/4"	2.17	2.64	1.25	0.73
105-607G	1-1/2"	2.34	2.74	1.50	0.71
105-608G	2"	3.15	3.31	2.00	0.83