

Hydronic Union

600 WOG

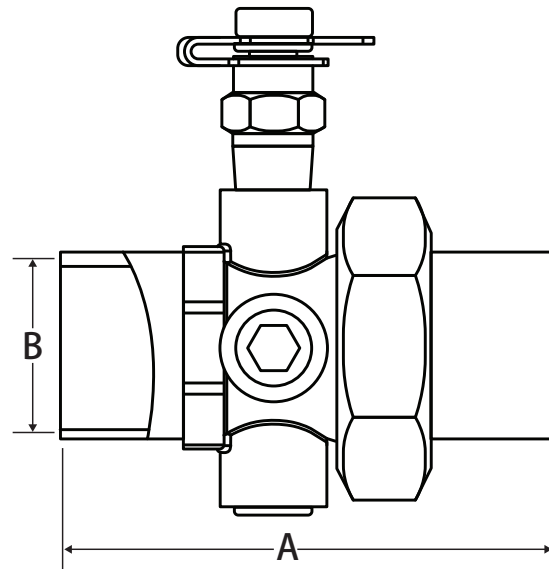

Terminator U



Features

- Pressure / temperature (PT) test ports
- Additional accessory taps
- 100% leak tested

Pressure and Temperature Rating

- 600 WOG
- 325°F Max

Smart Part Number Ordering Guide

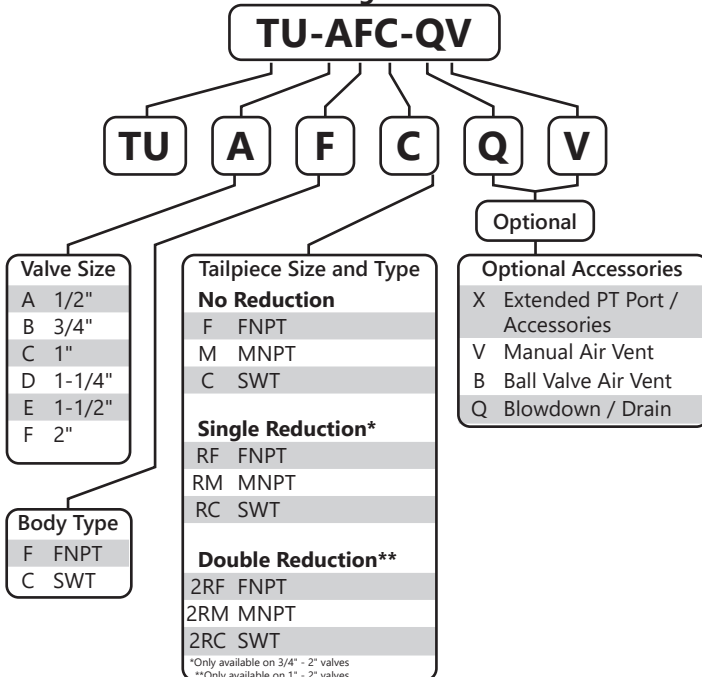

Material Specifications

Part	Material
Body	Brass - CW617N
O-ring	EPDM
Tail Piece	Brass - CW617N
Union Nut	Brass - CW617N

Dimensions

Size	A	B
1/2"	2.30	0.63
3/4"	3.10	0.88
1"	3.28	1.13
1-1/4"	3.99	1.38
1-1/2"	3.86	1.63
2"	4.65	2.13

Note: Dimensions for a SWT x SWT valve, additional dimensions available upon request



WARNING: This product can expose you to chemicals including lead, which is known to the State of California to cause cancer, and lead, which is known to the State of California to cause birth defects or other reproductive harm. For more information go to www.P65Warnings.ca.gov.